

# Masoneilan™ 33000 Series

Butterfly Valves

Instruction Manual (Rev.C)

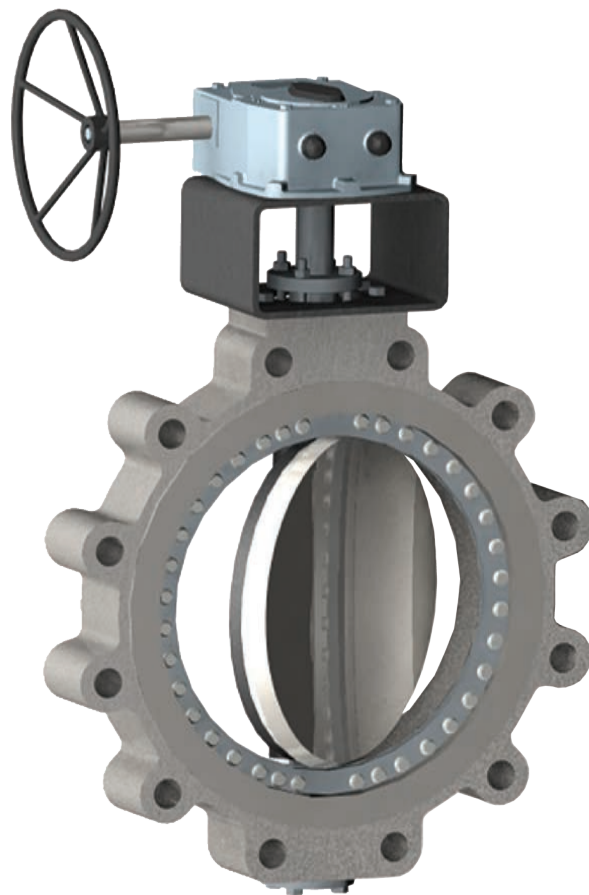

**THESE INSTRUCTIONS PROVIDE THE CUSTOMER/OPERATOR WITH IMPORTANT PROJECT-SPECIFIC REFERENCE INFORMATION IN ADDITION TO THE CUSTOMER/OPERATOR'S NORMAL OPERATION AND MAINTENANCE PROCEDURES. SINCE OPERATION AND MAINTENANCE PHILOSOPHIES VARY, BAKER HUGHES COMPANY (AND ITS SUBSIDIARIES AND AFFILIATES) DOES NOT ATTEMPT TO DICTATE SPECIFIC PROCEDURES, BUT TO PROVIDE BASIC LIMITATIONS AND REQUIREMENTS CREATED BY THE TYPE OF EQUIPMENT PROVIDED.**

**THESE INSTRUCTIONS ASSUME THAT OPERATORS ALREADY HAVE A GENERAL UNDERSTANDING OF THE REQUIREMENTS FOR SAFE OPERATION OF MECHANICAL AND ELECTRICAL EQUIPMENT IN POTENTIALLY HAZARDOUS ENVIRONMENTS. THEREFORE, THESE INSTRUCTIONS SHOULD BE INTERPRETED AND APPLIED IN CONJUNCTION WITH THE SAFETY RULES AND REGULATIONS APPLICABLE AT THE SITE AND THE PARTICULAR REQUIREMENTS FOR OPERATION OF OTHER EQUIPMENT AT THE SITE.**

**THESE INSTRUCTIONS DO NOT PURPORT TO COVER ALL DETAILS OR VARIATIONS IN EQUIPMENT NOR TO PROVIDE FOR EVERY POSSIBLE CONTINGENCY TO BE MET IN CONNECTION WITH INSTALLATION, OPERATION OR MAINTENANCE. SHOULD FURTHER INFORMATION BE DESIRED OR SHOULD PARTICULAR PROBLEMS ARISE WHICH ARE NOT COVERED SUFFICIENTLY FOR THE CUSTOMER/OPERATOR'S PURPOSES THE MATTER SHOULD BE REFERRED TO BAKER HUGHES.**

**THE RIGHTS, OBLIGATIONS AND LIABILITIES OF BAKER HUGHES AND THE CUSTOMER/OPERATOR ARE STRICTLY LIMITED TO THOSE EXPRESSLY PROVIDED IN THE CONTRACT RELATING TO THE SUPPLY OF THE EQUIPMENT. NO ADDITIONAL REPRESENTATIONS OR WARRANTIES BY BAKER HUGHES REGARDING THE EQUIPMENT OR ITS USE ARE GIVEN OR IMPLIED BY THE ISSUE OF THESE INSTRUCTIONS.**

**THESE INSTRUCTIONS ARE FURNISHED TO THE CUSTOMER/OPERATOR SOLELY TO ASSIST IN THE INSTALLATION, TESTING, OPERATION, AND/OR MAINTENANCE OF THE EQUIPMENT DESCRIBED. THIS DOCUMENT SHALL NOT BE REPRODUCED IN WHOLE OR IN PART WITHOUT THE WRITTEN APPROVAL OF BAKER HUGHES.**

# Table Of Contents

<b>Safety Information</b> .....	<b>4</b>
About this Manual .....	4
Useful Life Period.....	4
Warranty.....	4
<b>1. Introduction</b> .....	<b>5</b>
<b>2. Description</b> .....	<b>5</b>
<b>3. Numbering System</b> .....	<b>6</b>
<b>4. Operation</b> .....	<b>7</b>
<b>5. Overhaul &amp; Refurbishment</b> .....	<b>7</b>
<b>6. Functional Safety</b> .....	<b>7</b>
<b>7. Unpacking</b> .....	<b>8</b>
<b>8. Installation</b> .....	<b>8</b>
<b>9. Air Piping</b> .....	<b>8</b>
<b>10. Body Disassembly</b> .....	<b>9</b>
Disc Seat 2-piece design .....	9
All sizes 150 and 300 and 6in and above 600 class .....	9
Single Disc 3 and 4 in sizes 600 Class .....	9
<b>11. Maintenance and Repair</b> .....	<b>10</b>
Preventative Maintenance.....	10
<b>12. Valve Body Reassembly</b> .....	<b>10</b>
Disc Seat 2-Piece Design - Standard.....	10
Single Disc 3 and 4 inch sizes class 600 (Keyed Shaft Assembly).....	11
<b>13. Setting Procedure - Sealing Components</b> .....	<b>12</b>
<b>14. Protection, Storage &amp; Handling</b> .....	<b>12</b>
<b>15. 33000 Series Body Information</b> .....	<b>14</b>
<b>16. Actuators</b> .....	<b>15</b>
33000 Series 31/32 Actuators .....	16
33000 Series Rotork Actuators .....	17-18
33000 Series Parts Reference .....	19-20

## Torque Tables:

Table-1: All Fasteners except Seat Ring & End Plate .....	22
Table-2: End Plate Fastener (B913a) CL 150/300 .....	23
Table-4: End Plate Fastener (B913a) CL600 .....	23
Table-3: Seat Ring Fastener (B913b) CL 150/300 .....	23
Table-5: Seat Ring Fastener (B913b) CL 600 .....	23

## Table of Figures

Figure 1: Indicator of Gearbox or Actuator .....	14
Figure 2: 33000 Series Valve Body Types .....	14
Figure 2a: Lugged Tapped Body .....	14
Figure 2b: Lugged Drilled Body.....	14
Figure 2c: Double Flanged Short Pattern Body .....	14
Figure 2d: True Wafer Body .....	14
Figure 3: Actuators for Different Variants .....	15
Figure 4: Actuator Mounting Positions .....	16
Figure 5: Rotork Actuator (CP/GP) Mounting Positions .....	17
Figure 6: Manual Operator Gearbox .....	18
Figure 7: 33000 Series (except 3" CL 600 and 4" CL 600) .....	19
Figure 8: 33000 Series 3" CL 600 and 4" CL 600 .....	20
Figure 9: Packing Set.....	21

## Safety Information

### Important - Please Read Before Installation

These instructions contain **DANGER**, **WARNING**, and **CAUTION** labels, where necessary, to alert you to safety related or other important information. Read the instructions carefully before installing and maintaining your control valve. **DANGER** and **WARNING** hazards are related to personal injury. **CAUTION** hazards involve equipment or property damage. Operation of damaged equipment can, under certain operational conditions, result in degraded process system performance that can lead to injury or death. Total compliance with all **DANGER**, **WARNING**, and **CAUTION** notices is required for safe operation.



This is the safety alert symbol. It alerts you to potential personal injury hazards. Obey all safety messages that follow this symbol to avoid possible injury or death.



Indicates a potentially hazardous situation which, if not avoided, could result in death or serious injury.



Indicates a potentially hazardous situation which, if not avoided, could result in serious injury.



Indicates a potentially hazardous situation which, if not avoided, could result in minor or moderate injury.



When used without the safety alert symbol, indicates a potentially hazardous situation which, if not avoided, could result in property damage.

**Note: Indicates important facts and conditions.**

## About this Manual

- The information in this manual is subject to change without prior notice.
- The information contained in this manual, in whole or part, shall not be transcribed or copied without Baker Hughes's written permission.
- Please report any errors or questions about the information in this manual to your local supplier.
- These instructions are written specifically for the 33000 Series Butterfly valves, and do not apply for other valves outside of this product line.

## Useful Life Period

The current estimated useful life period for the 33000 Series Butterfly valves is 25+ years. To maximize the useful life of the product, it is essential to conduct annual inspections, routine maintenance and ensure proper installation to avoid any unintended stresses on the product. The specific operating conditions will also impact the useful life of the product. Consult the factory for guidance on specific applications if required prior to installation.

## Warranty

Items sold by Baker Hughes are warranted to be free from defects in materials and workmanship for a period of one year from the date of shipment provided said items are used according to Baker Hughes recommended usages. Baker Hughes reserves the right to discontinue manufacture of any product or change product materials, design or specifications without notice.

### Note: Prior to installation:

- The valve must be installed, put into service and maintained by qualified and competent professionals who have undergone suitable training.
- All surrounding pipe lines must be thoroughly flushed to ensure all entrained debris has been removed from the system.
- Under certain operating conditions, the use of damaged equipment could cause a degradation of the performance of the system which may lead to personal injury or death.
- Changes to specifications, structure, and components used may not lead to the revision of this manual unless such changes affect the function and performance of the product.

# 1. Introduction

The following instructions should be thoroughly reviewed and understood prior to installing, operating or performing maintenance on this equipment. Throughout the text, safety and/or caution notes will appear and must be strictly adhered to, otherwise, serious injury or equipment malfunction could result.

Baker Hughes has a highly skilled After Sales Department available for start-up, maintenance and repair of our Masoneilan valves and component parts.

Arrangements for this service can be made through your local Baker Hughes Representative or After Sales Department. When performing maintenance use only Masoneilan replacement parts. Parts are obtainable through your local Baker Hughes Representative or Spare Parts Department. When ordering Masoneilan parts, always include Model and Serial Number of the unit being repaired.

Baker Hughes valves can be used as control or shut off valves. They are offered in a number of body styles and valve trims. The type of duty will dictate the trim selected.

Always know what the valve has to do and specify it accordingly. Important points to consider are: type of fluid, pressure, temperature, thermal and mechanical pipe strains, hydraulic tests, water hammer, thermal shocks, PED2014/68/EU (where applicable), NACE MR0175, corrosion, environmental conditions and valve orientation.

# 2. Description

These installation and maintenance instructions apply to all sizes and ratings of the Masoneilan 33000 Series control valves.

The 33000 valve series is a Triple Offset Butterfly valve which incorporates new performance enhancing operational features, allowing for a more simplified manufacturing process. It offers high capacity while providing excellent seat leakage performance in both directions. The ability to quick removal and replacement of the valve components during maintenance saves valuable plant downtime.

# 3. Numbering System

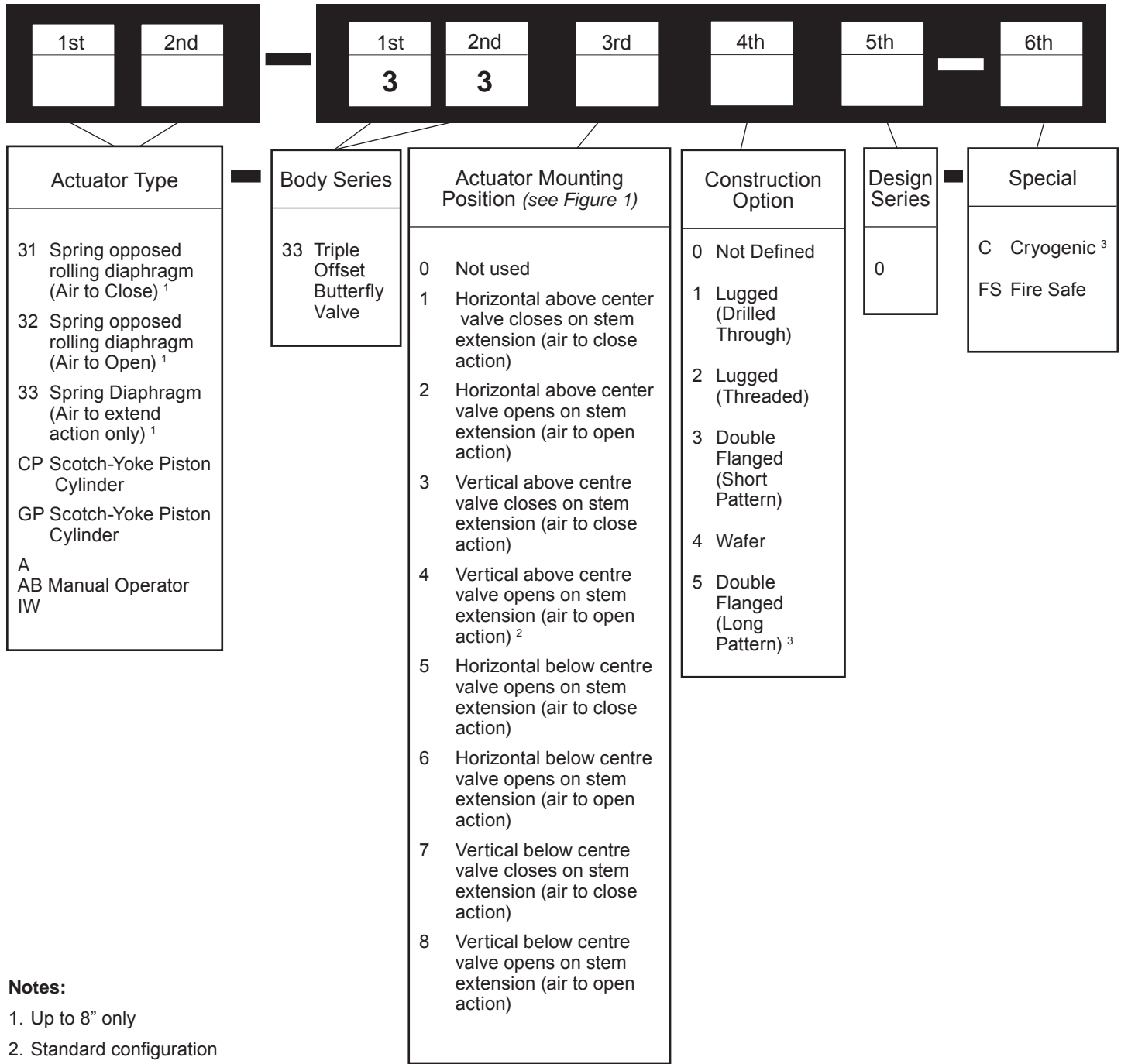

## 4. Operation

Ensure that operators and fitters are fully trained and familiar with the procedures to be undertaken. For both electrical and pneumatic equipment ensure the operator has carefully read the manufacturer's instructions.

Never on valves that employ a manual override, shaft mounted de-clutchable gearbox, engage the gearbox with the valve on automatic control. The handwheel must be disengaged prior to the unit being operated under its automatic condition.

Unless the valve is specifically designed for fast operation, valves should be operated slowly to avoid thermal and mechanical shocks.

Never use the Mounting Box to support an Actuator; the Mounting Box is designed to transfer torque through the drive chain not to fully support the weight of an overhanging Actuator.

Always ensure Actuation is fully supported on installation and once in position.

**Note: The High-Performance Triple Offset Butterfly Valve is a 'Torque Seated' design. To operate the valve effectively torque must be applied throughout the drive chain to the sealing components (explanation: effectively the valve is trying to over-close)**

To adequately achieve closure, a Masoneilan Valve requires;

A minimum of '5° over-travel' to be incorporated into the operator design.

The drive-chain must be rigid through the use of dowel pins or a calculated bolting sequence.

Sealing components must not be adjusted or removed without authorization from Baker Hughes in writing. To do so will invalidate any warranty. Never remove the valve obturator when the valve is under pressure or in service.

Masoneilan Valve Triple Offset Butterfly Valves are quarter turn operational valves. Valve users must ensure actuation is set to prevent the valve from opening past 90 degrees.

Baker Hughes will supply the effective torques required to seal the Masoneilan valve and MAST / MAVIT figures on request.

Never remove the valve actuation or gearbox when the valve is under pressure or in service.

The function of a butterfly valve is to isolate or regulate flow. The closing mechanism takes the form of a disc which allows for quick shut off. Butterfly valves are generally favored because they are lighter in weight, meaning less support is required. The disc is positioned in the center of the pipe, passing through the disc is a shaft connected to an actuator on the outside of the valve. Rotating the actuator turns the disc either parallel or perpendicular to the flow. The disc is always present within the flow; therefore, a pressure drop is always induced in the flow, regardless of valve position.

The offset position of the disc increases the valve's sealing ability and decreases its tendency to wear. The triple offset butterfly valve makes use of a metal seat and is therefore well suited to withstand higher pressure.

Operating specifications such as temperature and pressure are based on design and material choice.

Valves are manufactured to the Customer's requirements and operating parameters; manual or automated and defined in an order specific Quality Design Plan.

## 5. Overhaul and Refurbishment

The ability to undertake valve overhaul and refurbishment will be hindered by the restraints of the valve repair facilities and tooling at site of installation. Masoneilan Valve offers a return service. It is strongly recommended that the services of Masoneilan Valve be sought for valve overhaul and refurbishment where full engineering capability and access to specialist equipment exist.

If repair and refurbishment is to be undertaken at site by the end user, reference should be made to the Technical Instruction specific to the Butterfly valve type being repaired.

Only genuine Masoneilan Valve spares should be used. All Masoneilan Valve, valves are identified with a valve serial number. This serial number should be quoted with any technical query, spare parts or service inquiry.

For free refurbishment / overhaul quotations please contact

## 6. Functional Safety

The Safety Function of the valve is to move the disc to a predefined safe position upon a demand (manual or automated). The safe position can be to close or open.

Normal operation under a no fault condition where the valve is to close rather than open (or vice versa) it will behave as follows:

- The valve will be open allowing the process to flow
- Demand (manual or automated) is given to close the disc and isolate the process
- Shaft rotates
- Disc rotates with the shaft 90° until flush with the disc seat
- The valve is now fully sealed by the disc and the process is isolated



## 7. Unpacking

Care must be exercised when unpacking the valve to prevent damage to the accessories and component parts. Should any problems arise, contact the local Baker Hughes Representative or After Sales Department.

## 8. Installation

Before installing the valve in the line, clean piping and valve of all foreign material such as welding chips, scale, oil, grease or dirt. Gasket surfaces should be thoroughly cleaned to insure leak-proof joints.

To allow for in-line inspection, maintenance or removal of the valve without service interruption, provide a manually operated stop valve on each side of the 33000 Series valve with a manually operated throttling valve mounted in the by-pass line (See Figure X).

The valve must be installed so that the controlled substance will flow through the valve in the direction indicated by the flow arrow located on the body (See Figure 11).

1. Always read the installation instructions carefully and work to them.
2. The preferred orientation of a Butterfly valve is horizontal. Butterfly valves may be installed in other orientations, but deviations from this position, if not specified at the time of order, could compromise performance.
3. Always remove all external and internal packaging together with any temporary protective material.
4. Always carefully inspect the valve to ensure that no damage has occurred in transit or during subsequent handling.
5. Care should be taken to prevent any foreign matter finding its way through the valve during installation, which may cause damage to the valve internals and inhibit good valve performance.
6. Always ensure that the valve is installed so that it can be safely operated and maintained without putting persons at risk.
7. Always ensure adjoining pipework and connections are square, true and adequately supported to prevent the valve being subjected to stresses, which could affect its performance.
8. Always ensure that the bolted connections are tightened evenly to avoid placing a strain on the body/flanges.
9. Always ensure that the system into which the valve is to be installed is clean and free from any foreign matter.
10. Never remove fitted components when valve(s) are being installed - to do so will invalidate any warranty.
11. Always ensure that fast moving parts, which have a velocity greater than 12mm per second, are guarded.

12. Always ensure that valves, which operate at high or low temperatures, are positioned or lagged to prevent personnel contacting surfaces, which could cause injury.
13. Before chemical cleaning, flush the valve with water under a moderate pressure and operate the valve to allow the gland packing to be saturated with water, this will prevent the absorption of chemicals. During chemical cleaning, have the valve in the half open position to create turbulence; this will create the best cleaning effect. Passivate, and then flush with water. With water in the valve, operate it several times to flush away any chemicals that may have penetrated the gland packing. If the valves are not to be used immediately, use corrosion inhibitor in the water.
14. Always check with Baker Hughes prior to chemical cleaning to ensure that no degradation of any sealing elements will take place because of chemical attack.
15. Care should be taken not to over pressurize the system during hydraulic testing. Use corrosion inhibited water where necessary.
16. Function test the valve and system to ensure they are working as intended. Manually rotate the spindle of the valve to make sure that the vane clears the flanges and pipe when it moves to the open position. (Note for power actuated valves, disconnect the linkage before attempting to rotate the shaft). Ensure power or air supplies are safe and correct e.g. that electric actuators run in the correct direction, any limit switches trip at the correct position and that devices are available to isolate the electricity supply.

## 9. Air Piping

The actuators are designed to accept 1/4" NPT air supply piping. Use 1/4" OD tubing (4 x 6 mm) or equivalent for all air lines. If the supply airline exceeds 25 feet in length (7 meters) or if the valve is equipped with volume boosters, then 3/8" tubing (6 x 8 mm) is preferred. All connections must be free of leaks.

### CAUTION

**Do not exceed supply pressure indicated on serial plate located on the yoke of the actuator.**

# 10. Body Disassembly

Access to the internal components of the body should be accomplished with the actuator removed.

## CAUTION

Prior to performing maintenance on the valve, isolate the valve, vent the process pressure and vent the pneumatic actuator. Shut off the supply airline and the pneumatic or electric signal line.

Note : End gaskets are standard in the 33000 Series design and it is imperative that new gaskets be installed each time the valve is disassembled.

### Disc Seat 2-piece design

### All sizes 150 and 300 and 6in and above 600 class (Figure 7)

After removing the actuator, disassemble the body using the following procedure:

## WARNING

During assembly or maintenance, and under operation in some conditions, the operators or technicians must be alert and aware of all possible pinch points or areas where there are moving or sliding components.

- A. Disconnect piping from any leak detector port on the valve body.
- B. Remove Seat Ring Cap Head Screw (B915).
- C. Remove Seat ring retainer (B105) followed by Seat ring (B102), seat ring gasket (B103).
- D. Remove disc seat flange hex bolt (B913).

## CAUTION

Care must be taken to avoid damage to the Disc, Disc seat and Shaft.

- E. Remove Disc seat (B138) and Disc (B137) from shaft.
- F. Remove end plate Hex bolt (B913a) clamped to End plate at the bottom.
- G. Remove End plate (B010) and End plate gasket (B015).
- H. Remove the Thrust Pad Flange Hex bolt (B915) clamped to shaft at the bottom.
- I. Remove Bearing (B011) and Bearing Protector (B208) from the end plate side.
- J. Remove Gland Hex nut (B201) and the gland (B213) from top of the body.
- K. Remove Gland packings (B206) (see Figure 9) followed by Gland packing ring (B202), Bearing (B011) and Bearing Protector (B208).

- L. Remove shaft (B123) from the body while holding the disc seat (B138) and remove the disc seat from the body.

### Single Disc 3 and 4 in sizes 600 Class (Figure 8)

After removing the actuator, disassemble the body using the following procedure:

## WARNING

During assembly or maintenance, and under operation in some conditions the operators or technicians must be alert and aware of all possible pinch points or areas where there are moving or sliding components.

- A. Disconnect piping from any leak detector port on the valve body.
- B. Remove Seat Ring Cap Head Screw (B915a).
- C. Remove Seat ring retainer(B105) followed by Seat ring (B102), seat ring gasket (B103).
- D. Remove Set screw (B914) from Disc.
- E. Remove End plate Hex bolt (B913a) clamped to End plate at the bottom.

## CAUTION

Care must be taken to avoid damage to the Disc and Shaft.

- F. Remove End plate (B010) and End plate gasket (B015).
- G. Remove the Thrust Pad Flange Hex bolt (B915) clamped to shaft at the bottom.
- H. Remove Bearing (B011) and Bearing Protector (B208) from the end plate side.
- I. Remove Gland Hex nut (B201) and the Gland (B213) from top of the body.
- J. Remove Gland packings (B206) (see figure 9) followed by Gland packing ring (B202), Bearing (B011), Bearing Protector (B208).
- K. While holding the disc seat (B138) remove the shaft (B123) and shaft key (B929) then remove the disc seat (B138) from the body.

## 11. Maintenance and Repair

The purpose of this section is to provide recommended maintenance and repair procedures. These procedures assume the availability of standard shop tools and equipment.

### Preventative Maintenance

The functioning and life of a Butterfly valve largely depends on proper maintenance. For this reason, guidance, should be taken from the following:

- A. Always read the Technical Instruction specific to the valve type being installed.
- B. Prior to any work being undertaken on valves, reference should always be made to site safety procedures.
- C. Periodic inspections should be undertaken to check that no damage has occurred that could affect valve performance.
- D. Check all valve joints if practicable, including the valve packing or gland seals for signs of leakage.
- E. Check for any signs of corrosion on the valve if lagging does not restrict this operation.
- F. Check that all clamp nuts, screws, bolts etc. are tight.
- G. Check that all shaft packing is tight. Adjustment may be required to prevent stem leakage.

Where practical, establish that the valve is free to operate. Baker Hughes recommends regular cycling of its product to ensure free movement of the drive-chain (minimum weekly). Shafts, gearing and other moving components outside of the valve internals should be lubricated frequently. If the valve is not free to operate this could indicate internal problems.

Any remedial action that requires valve removal and refurbishment should be noted and undertaken at the earliest convenience. Problems that could affect operational safety should be addressed immediately.

## 12. Valve Body Reassembly

After completion of the required maintenance, the valve should be reassembled using the following procedures:

**Note: If any of the following steps were completed during maintenance, then proceed to the next step.**

### Disc Seat 2-Piece Design - Standard (Figure 7)

After removing the actuator, disassemble the body using the following procedure:

#### **WARNING**

**During assembly or maintenance, and under operation in some conditions the operators or technicians must be alert and aware of all possible pinch points or areas where there are moving or sliding components.**

- A. Attach the Thrust Pad (B139) to the end of the Shaft with Cap-head Bolts (B915).
- B. Apply MOLYKOTE(R) 321 DRY FILM LUBRICANT or equivalent to the Bearings (B011) and Shaft (B123) bearing surfaces. Allow 5-minute drying period.  
**Note: Air can be used to assist drying of the applied coating as shown below.**
- C. Remove excess film coating from Bearing and shaft surface using cloth or scrubber.
- D. Insert Bearing Protectors (B208) into Valve Body (B001) bore. Apply MOLYBDENUM GREASE or equivalent to the outer diameter of the Bearings and/or inner diameter of the body bore. Insert required number of Bearings into either end of the valve body. Apply MOLYBDENUM GREASE or equivalent to inside surface of the Bearing.  
**Note: Chamfered Edge of the Bearing should enter first while inserting the Bearing. Ensure Bearing is properly seated on the Bearing Protector.**
- E. Coat the bearing surfaces of the Shaft (B123) with the MOLYBDENUM GREASE or equivalent and carefully pass the Shaft through the Bearings, avoiding damage to the Bearing Protectors (B208). Rotate the Shaft 360° to allow the Thrust Pad(B139) to self-center in the Body Bore and lock the Cap-head Bolts(B915) in position to the required torque.
- F. With the Shaft in position attach the End Plate (B010) (without End Plate Gasket (B015)) and lock down to compress the Bearing Protector in the Body bore. Wait for one minute to allow the end plate(B010) to compress the shaft.

- G. Remove the End Plate. Check free rotation of the shaft. Tight the thrust pad Bolts (B915) using Allen key by holding shaft square using spanner.
- H. Apply a thin layer of MOLYBDENUM GREASE or equivalent to the gasket sealing area and Loctite 222 or equivalent on the required End Plate Bolting (B913a). Re-fit the End Plate including Gasket (B015) using the torques specified on the Table-2.
- I. Rotate the Shaft 360° - if there is no free rotational movement the fitter shall repeat step 6. If there is a high- spot or notable abrasion the fitter shall repeat step E.
- J. At the opposite end of the Valve Body, carefully insert the Gland Packing Ring (B202) and then the first of two Braided Packing pieces (B206). Insert 3 off Passivated Packing pieces (B206), lightly greased. Apply the second Braided Packing piece (B206) (position the split end at 180° to the first piece) and compact using the Gland (B213) or specific compression tool.

**Note: do not over compress packing; ensure free rotational movement of Shaft.**

- K. Apply Loctite 222 or equivalent to the Threaded Studs (B200). Screw the studs into position and lock. Position the Gland (B213) over the Shaft and loosely secure with Nuts (B201) supplied. Do not compress Packing.
- L. Fit the Disc (B137) over the Shaft ensuring the machined line on the end of the Shaft is in parallel.
- M. Offer the mating Disc Seat (B138) into position. Secure using required bolting (B913) (bolting should be lightly greased with MOLYKOTE® 1000 PASTE or equivalent on the thread and shoulder to allow correct input torque). Tighten the bolts (B913) 'finger tight' and release by one half turn - do not apply torque.

**Note: Disc Seat (B138) Angled side bottom and flat side top.**

- N. Place the Seat Ring Gasket (B103), Seat Ring (B102) and Retainer (B105) into the Body Counter bore. Secure with required bolting (bolting should be lightly greased with MOLYKOTE® 1000 PASTE or equivalent on the thread and shoulder to allow correct input torque). Tighten the bolts 'finger tight' and release by one complete turn - do not apply torque.

**Note: Seat Ring Orientation should match with that of Disc, i.e. Flat side of Seat Ring and that of Disc should match.**

## Single Disc 3 and 4 inch sizes class 600 (Keyed Shaft Assembly) (Figure 8)

After removing the actuator, disassemble the body using the following procedure:

### WARNING

**During assembly or maintenance, and under operation in some conditions the operators or technicians must be alert and aware of all possible pinch points or areas where there are moving or sliding components.**

Place the valve body (B001) in the still position.

- A. Repeat steps A to D from previous section "Disc Seat 2-Piece Design"
- B. Insert the Key(B929) into the keyway of the shaft(B123) and Coat the bearing surfaces of the shaft(B123) with MOLYBDENUM GREASE or equivalent.
- C. Hold the Integrated disc and disc seat(B138) in the bore of the Valve and carefully pass the shaft(B123) through the cross bore from the Gland (B213) end, align the key(B929) with the keyway in the Integrated disc and Disc Set(B138) and pass the shaft(B123) through the endplate(B010) end of the cross bore avoiding damage to the bearing protectors(B208).
 

**Note: Integrated Disc and Disc seat(B138) angled side bottom and bottom side**
- D. Tighten the Integrated disc and disc seat(B138) with shaft(B123) using Grub screw(B914). Ensure that machined line at the shaft is parallel to the disc.
- E. Attach the Thrust Pad(B139) to the end of the Shaft(B123) with Cap-head Bolts(B915) (threads may be covered with the specified grease – use of Loctite or equivalent is not permitted). Rotate the Shaft through 90° to allow the Thrust Pad(B139) to self-center in the Body Bore and lock the Cap-head Bolts(B915) in position.
- F. Repeat steps A to D from previous section "Disc Seat 2-Piece Design".

## 13. Setting Procedure Sealing Components

- A. Over-close the valve by means of Actuator operation or equivalent mechanism (Gear Box, Lever etc.) by approximately;
- 3 to 4 degrees - 3 Inch to 6 Inch
  - 2 to 3 degrees - 8 Inch to 10 Inch
  - 1 to 2 degrees - 12 Inch to 24 Inch

**Note: This will elevate the Seat Retainer slightly and should be repeated 3 or 4 times to ensure mating alignment of Disc Seat (B138) and Seat Ring (B102).**

- B. The Seat Ring Bolting (B913b) shall be tightened to half the required torque (ref. Table-3) in the sequence shown
- C. Flip the valve and tighten the Disc Bolting (B913) to the required torque (ref. Table-1)
- D. Return the valve to original position and tighten the Seat Ring Bolting (B913b) to the required torque (ref. Table-3) in the sequence indicated.

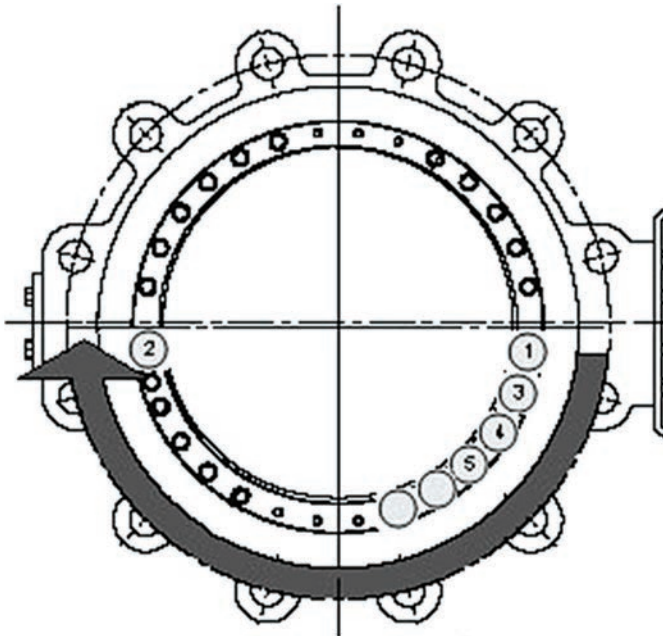

- E. Open the valve slightly and re-torque in the required sequence (This may need to be repeated 2 or 3 times due to compression of the seat ring laminate).
- F. The Bearing(B011) qty. may differ as there are Single bearing and two bearing constructions. Check the Parts list and respective assembly drawing for the quantity of bearing.

## 14. Protection, Storage and Handling

Butterfly valves have been tested and adjusted at the factory prior to shipment. The period between leaving the manufacturing plant to installation may involve substantial exposure to degradation due to impact, impingement or corrosion.

Such degradation can adversely affect the performance of valves when in service and can easily be avoided if simple guidelines are followed.

### A. Protection

As a minimum all Masoneilan Valve Butterfly valves are dried, coated and fitted with protective measures, such as valve end port protection and waterproof wrapping prior to shipment. Larger valves may have their own shipment cases. This protection should be left in place until immediately before the valve is to be fitted into the pipe.

### B. Storage

Valves are often stored at site for an extended period before they are actually installed. Storage should be in the original delivery crates with any waterproof lining and or desiccant remaining in place.

To avoid the possibility of any deterioration, storage should be off the ground in a clean, dry, indoor environment. If the storage period extends over six months, any desiccant bags supplied in the original packaging should be replaced.

### C. Handling

Appropriate care when handling valves should be given, roughness in handling may damage end connections or valve parts. Care should be taken to avoid damage to any protection. Valves that require handling by mechanical means should be slung or rigged carefully to avoid damage to exposed valve parts. It is critical that the lifting of the valve assembly is not at the actuator but at the valve itself.

### D. Transportation

Where able, the valve Disc Seat must be 'cracked off' the Body Seal during transportation. This is to prevent the possibility of damage to the sealing components through impact.

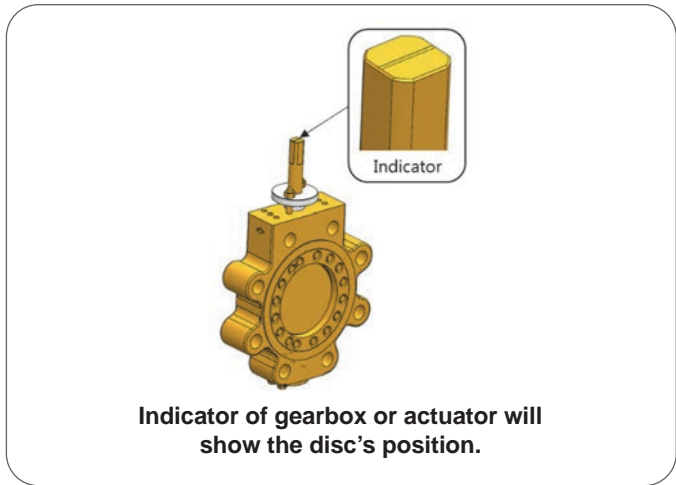

Figure 1: Indicator of Gearbox or Actuator

## 15. 33000 Series Body Information

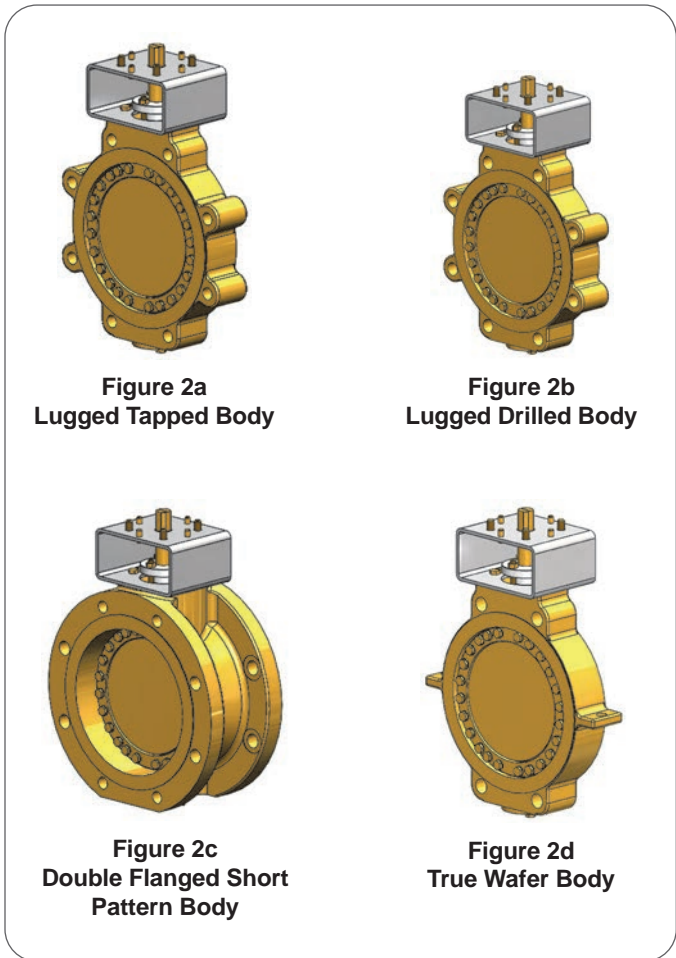

Figure 2: 33000 Series Valve Body Types

## 33000 Series Pressure Ratings

Valve Size (inches)	Valve Size (mm)	ASME Class	Class Max Pressure (Mpa)	
			WCC	CF3M / CF8M
3	80	150	1.98	1.9
		300	5.17	4.96
		600	10.34	9.93
4	100	150	1.98	1.9
		300	5.17	4.96
		600	10.34	9.93
6	150	150	1.98	1.9
		300	5.17	4.96
		600	10.34	9.93
8	200	150	1.98	1.9
		300	5.17	4.96
		600	10.34	9.93
10	250	150	1.98	1.9
		300	5.17	4.96
		600	10.34	9.93
12	300	150	1.98	1.9
		300	5.17	4.96
		600	10.34	9.93
14	350	150	1.98	1.9
		300	5.17	4.96
		600	10.34	9.93
16	400	150	1.98	1.9
		300	5.17	4.96
		600	10.34	9.93
18	450	150	1.98	1.9
		300	5.17	4.96
		600	10.34	9.93
20	500	150	1.98	1.9
		300	5.17	4.96
		600	10.34	9.93
24	600	150	1.98	1.9
		300	5.17	4.96
		600	10.34	9.93
30	750	150	1.98	1.9
		300	5.17	4.96
		600	10.34	9.93
36	900	150	1.98	1.9
		300	5.17	4.96
		600	10.34	9.93
42	1050	150	1.98	1.9
		300	5.17	4.96
		600	10.34	9.93
48	1200	150	1.98	1.9
		300	5.17	4.96
		600	10.34	9.93

# 16. Actuators

Masoneilan Types 31/32/33 Pneumatic actuators, spring-opposed rolling diaphragm.

## Actuator type based on Valve size

Valve Size	Actuator				
	Type	Effective area	Stroke	Spring range	Max. Supply Pressure
3" CL 150	33 Size B	450 cm <sup>2</sup> (70 sq. in)	66.5 mm ( 2" 5/8)	7 - 16 psi	2.4 bar (35 psi)
3" CL 300, 4" CL 150	33 Size C	900 cm <sup>2</sup> (140 sq. in)	66.5 mm ( 2" 5/8)	9 - 16 psi	
4" CL 300, 6" & 8"	31/32 Size D	387 cm <sup>2</sup> (60 sq. in)	101.6 mm (4")	12-28 psi	3.45 bar (50 psi)
				17-40 psi	4.83 bar (70 psi)
				29-68 psi	6.21 bar (90 psi)

- Pneumatic Scotch Yoke Actuator available option
- Rotork Actuator (SR)
- Gearbox

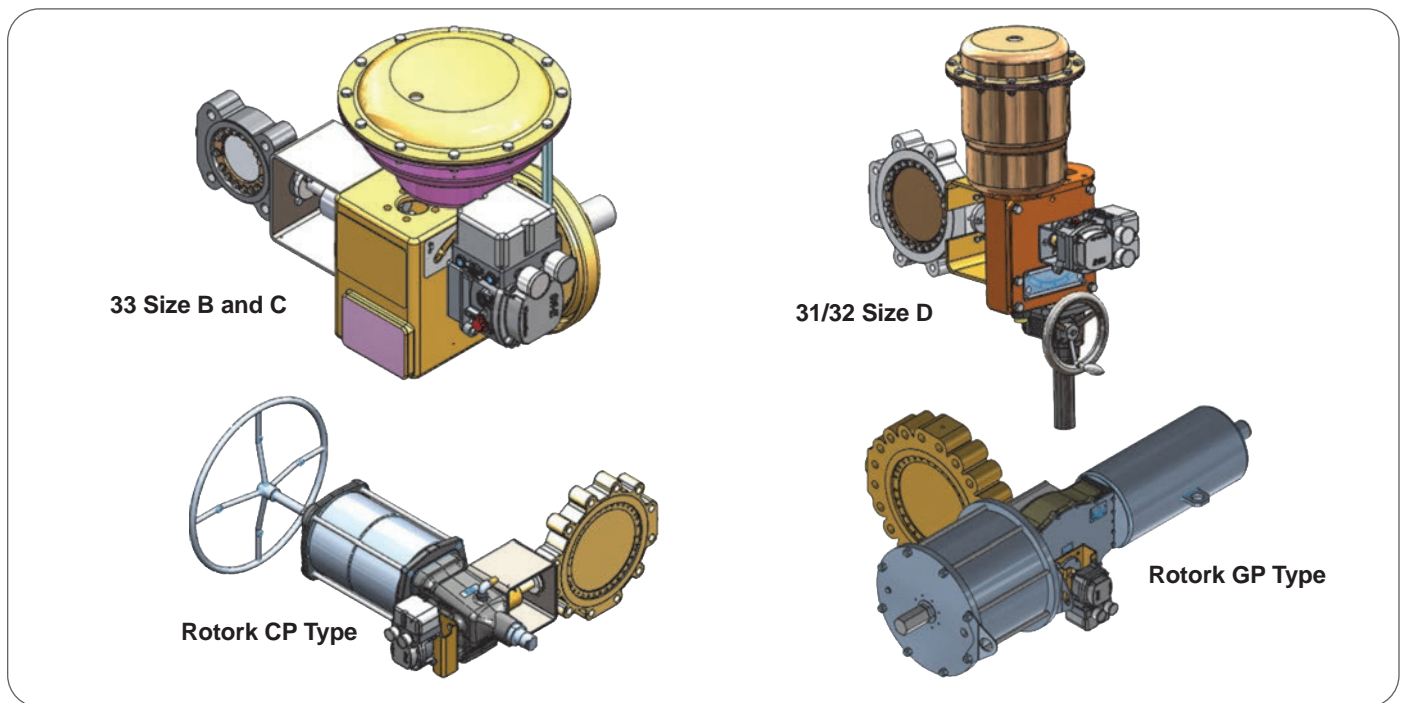
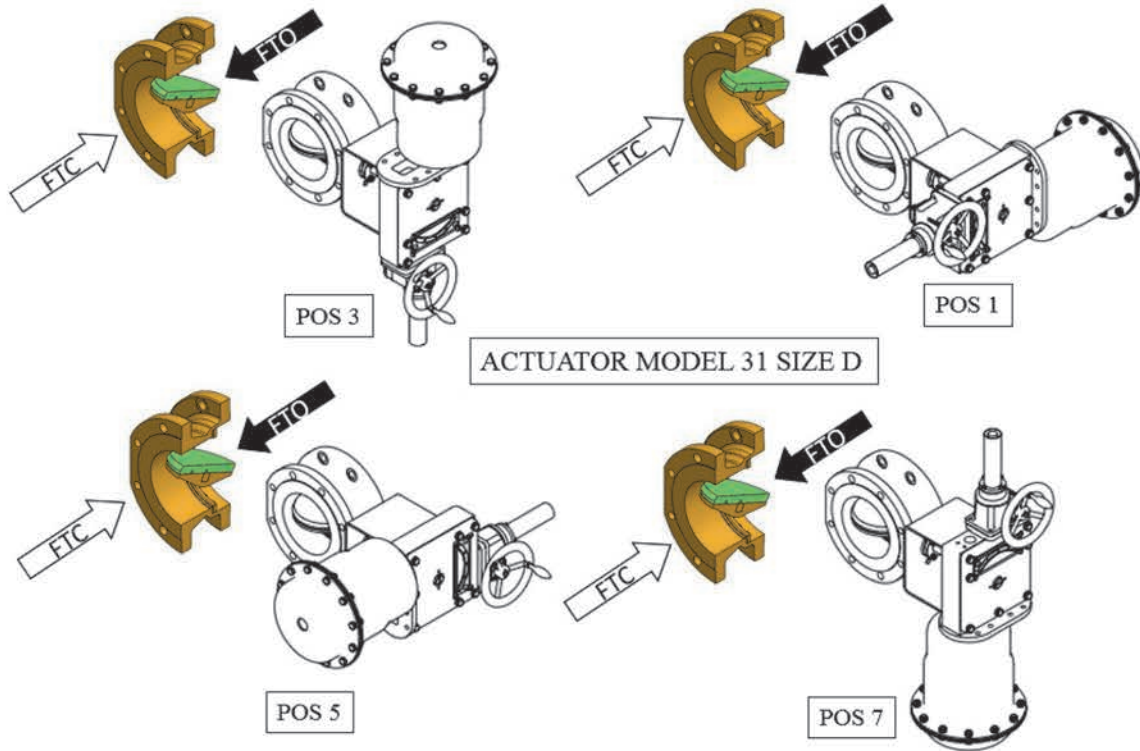

Figure 3: 33000 Series Valve Actuators for Different Variants

# 33000 Series 31/32 Actuators

## Air to Close



## Air to Open

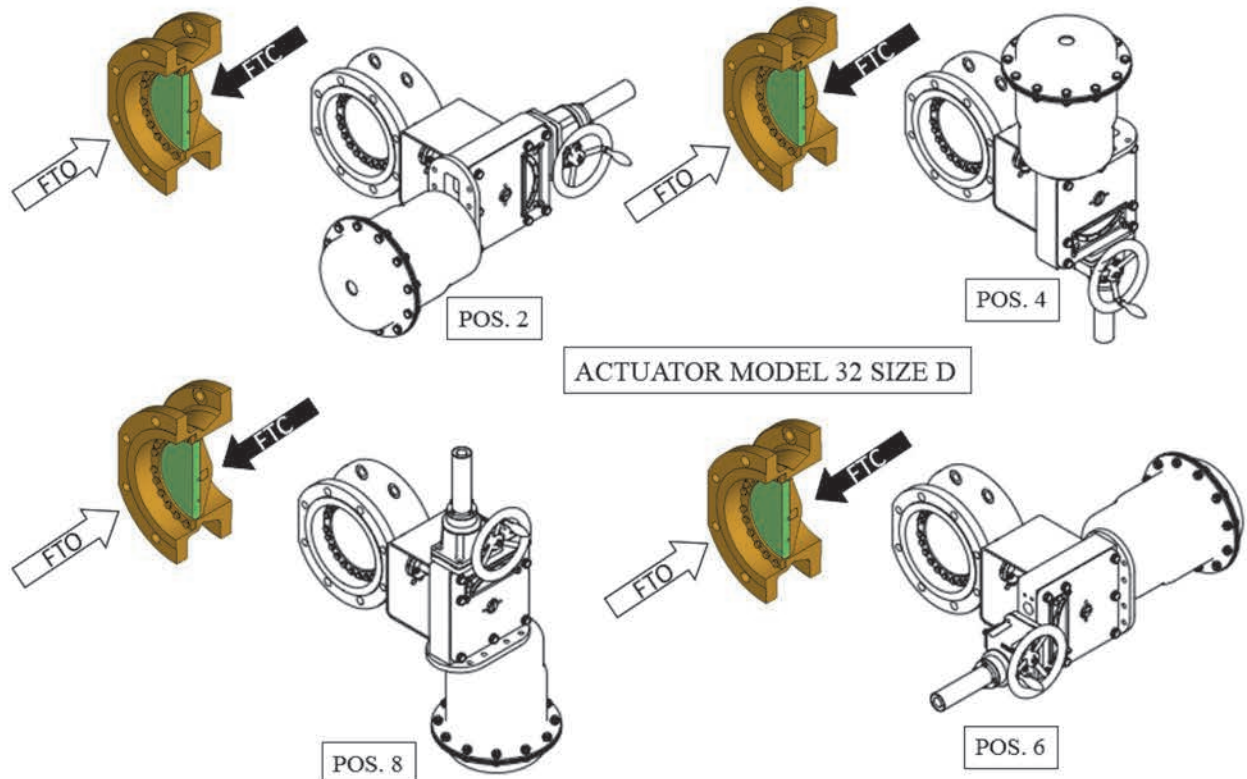
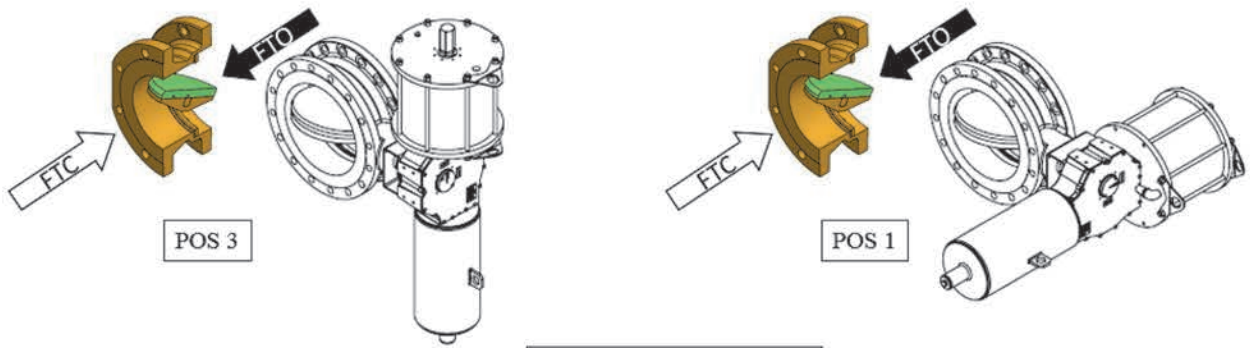

Figure 4: Actuator Mounting Positions



# 33000 Series Rotork Actuators

## Air to Close



ACTUATOR-ROTORK

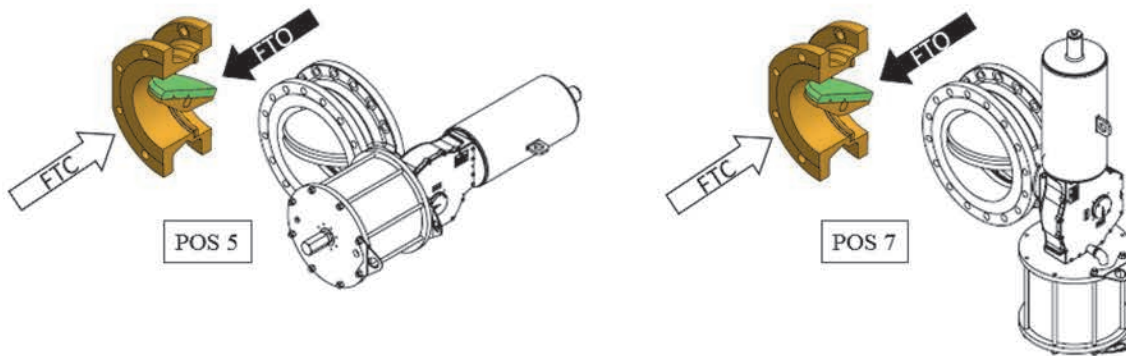

## Air to Open

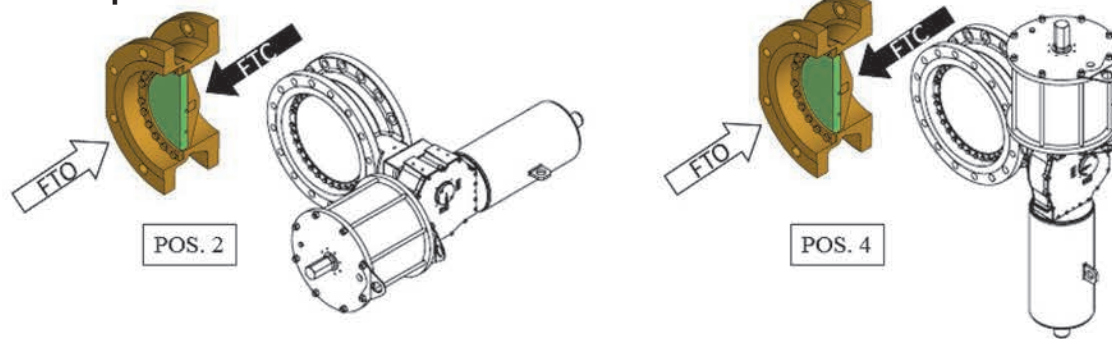

ACTUATOR-ROTORK

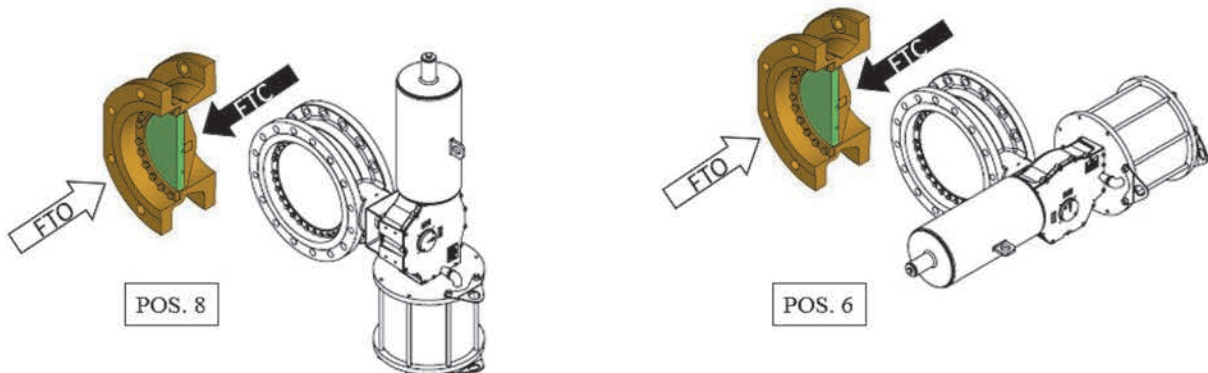

Figure 5: Rotork Actuator (CP/GP) Mounting Positions

# 33000 Series Rotork Actuators

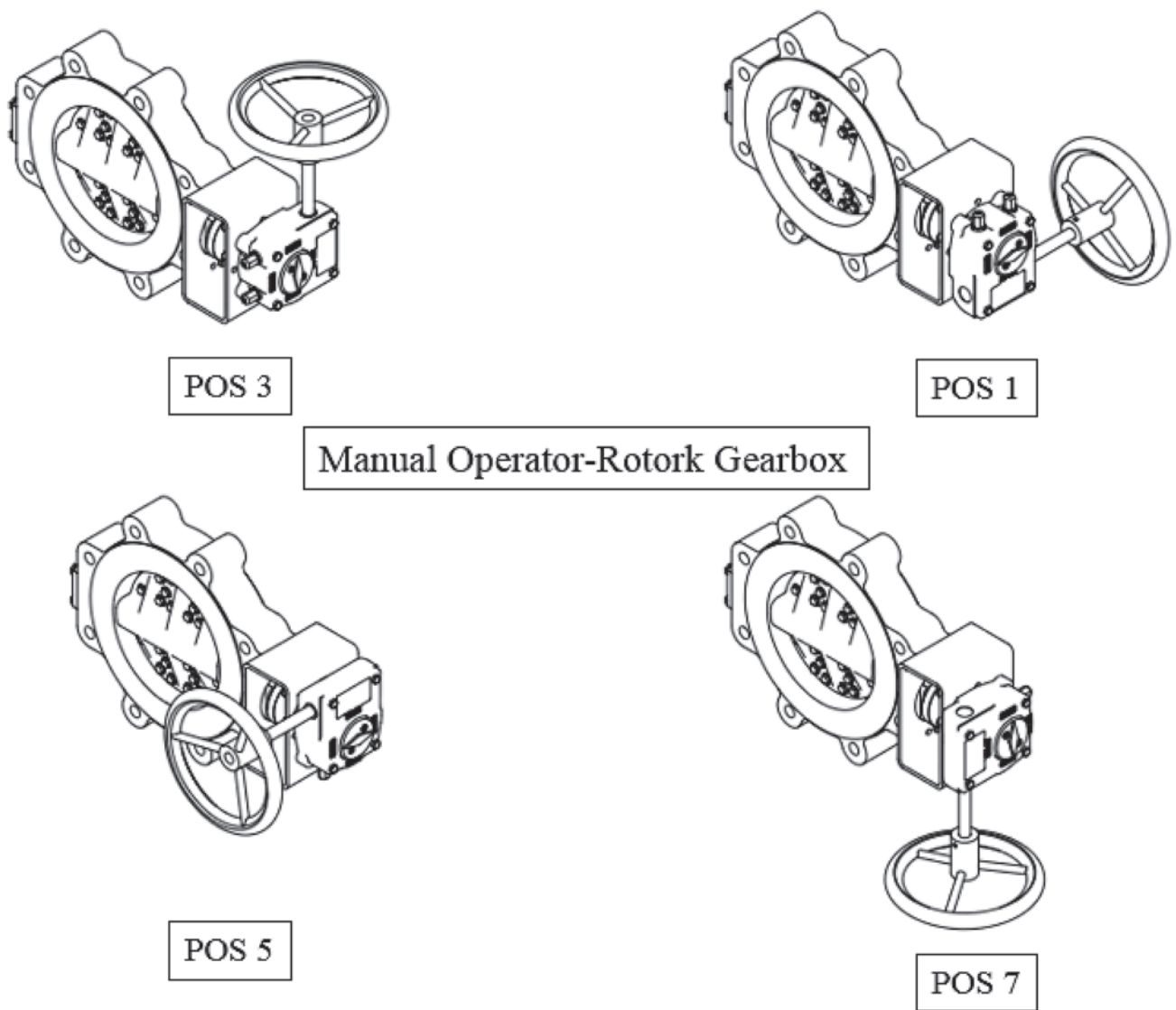
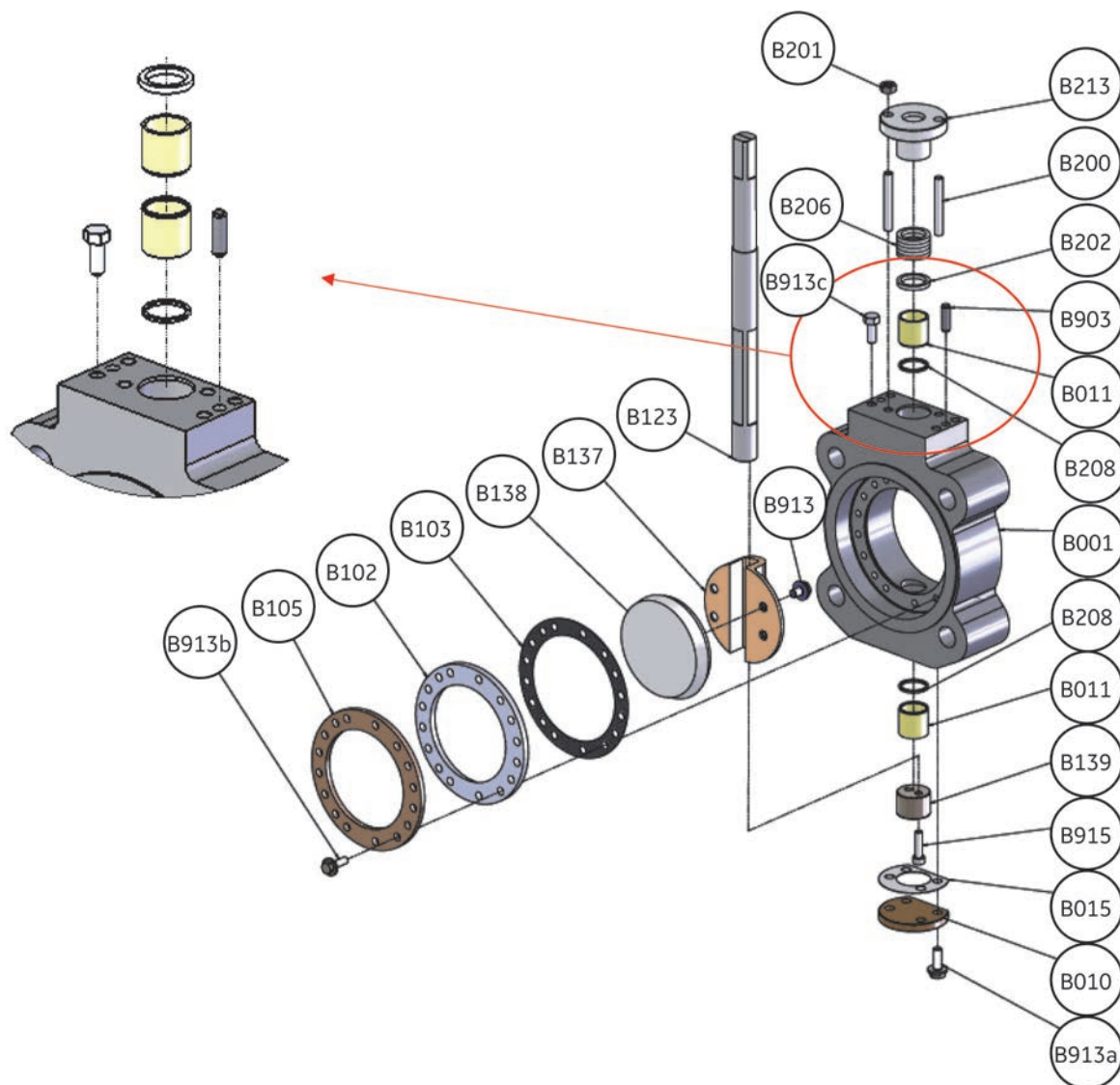

Figure 6: Manual Operator Rotork Gearbox

Note: Other positions are identical, so not shown/applicable for manual operator

## 33000 Series Parts Reference



PARTS REFERENCES					
CODE	DESCRIPTION	CODE	DESCRIPTION	CODE	DESCRIPTION
B001	BODY	B137	DISC	B213	GLAND
B010	END PLATE	B138	DISC SEAT	B903	DOWEL PIN
B011	BEARING	B139	THRUST PAD	B913	FLANGE HEX BOLT
B015	END PLATE GASKET	B200	FULL THREADED STUD	B913a	FLANGE HEX BOLT
B102	SEAT RING	B201	HEX NUT	B913b	CAP HEAD SCREW
B103	SEAT RING GASKET	B202	GLAND PACKING RING	B913c	FLANGE HEX BOLT
B105	SEAT RING RETAINER	B206	GLAND PACKING		
B123	SHAFT	B208	BEARING PROTECTOR		

Figure 7: 33000 Butterfly Valve (except 3" CL 600 and 4" CL 600)

# 33000 Series Parts Reference

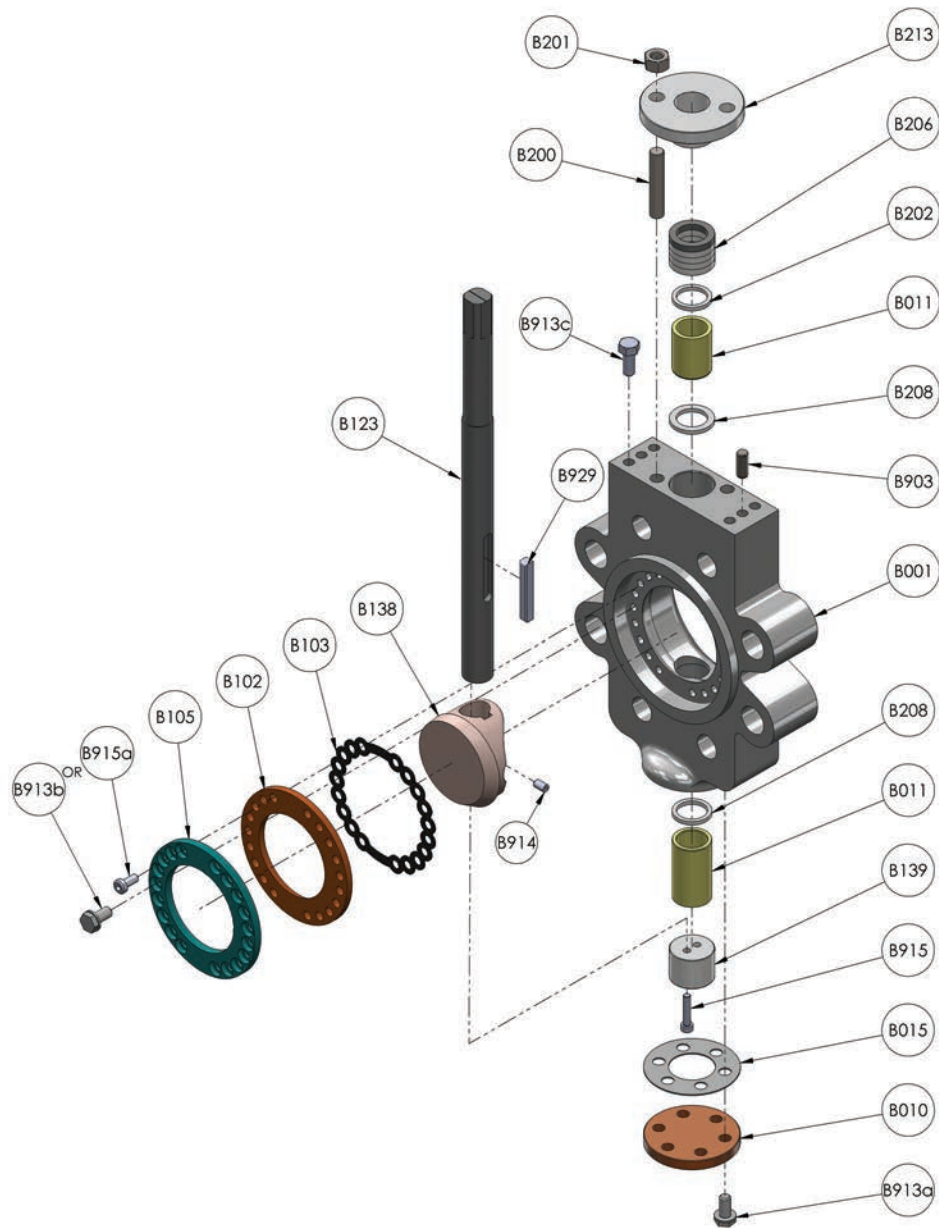

PARTS REFERENCES					
CODE	DESCRIPTION	CODE	DESCRIPTION	CODE	DESCRIPTION
B001	BODY	B138	DISC SEAT	B903	DOWEL PIN
B010	END PLATE	B139	THRUST PAD	B913a	FLANGE HEX BOLT
B011	BEARING	B200	FULL THREADED STUD	B913b	FLANGE HEX BOLT
B015	END PLATE GASKET	B201	HEX NUT	B913c	FLANGE HEX BOLT
B102	SEAT RING	B202	GLAND PACKING RING	B914	SET SCREW
B103	SEAT RING GASKET	B206	GLAND PACKING	B915	CAP HEAD SCREW
B105	SEAT RING RETAINER	B208	BEARING PROTECTOR	B915a	CAP HEAD SCREW
B123	SHAFT	B213	GLAND	B929	SHAFT KEY

Figure 8: 33000 Butterfly Valve 3" CL 600 and 4" CL 600

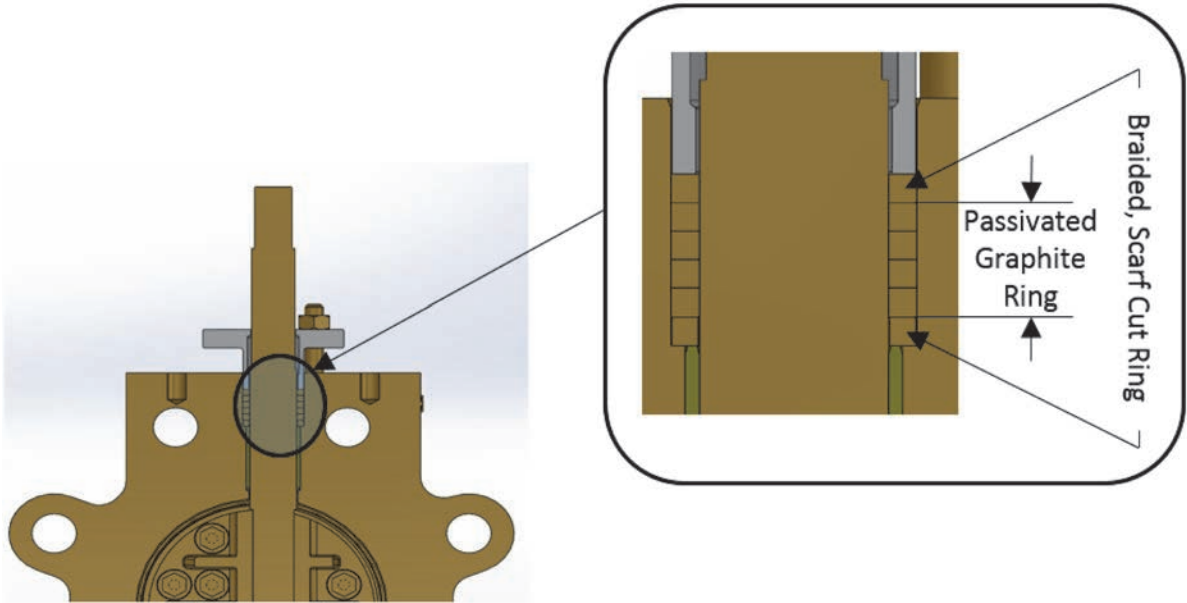

Figure 9: Packing Set

# 33000 Series Torque details

Table-1: All Fasteners except Seat Ring & End Plate

17-4 PH		
Bolt Size	Maximum torque	Recommended minimum torque
Standard	Nm	Nm
M4	5	3
M5	9	7
M6	16	11
M8	38	28
M10	76	55
M12	132	95
M14	211	152
M16	327	236
M20	639	461
M24	1104	797
M30	2195	1585
M36	3837	2771
M42	6144	4437
M48	9228	6665

A4-80		
Bolt Size	Maximum torque	Recommended minimum torque
Standard	Nm	Nm
M4	4	3
M5	8	6
M6	13	9
M8	32	23
M10	63	45
M12	109	79
M14	175	126
M16	271	196
M20	529	382
M24	914	660
M30	1816	1312
M36	3175	2293
M42	5084	3672
M48	7637	5515

UNS S32760 (DUPLEX)		
Bolt Size	Maximum torque	Recommended minimum torque
Standard	Nm	Nm
M4	5	3
M5	9	7
M6	16	11
M8	38	28
M10	76	55
M12	132	95
M14	211	152
M16	327	236
M20	639	461
M24	1104	797
M30	2195	1585
M36	3837	2771
M42	6144	4437
M48	9228	6665

MONEL K 500		
Bolt Size	Maximum torque	Recommended minimum torque
Standard	Nm	Nm
M4	5	3
M5	9	7
M6	16	11
M8	38	28
M10	76	55
M12	132	95
M14	211	152
M16	327	236
M20	639	461
M24	1104	797
M30	2195	1585
M36	3837	2771
M42	6144	4437
M48	9228	6665

NITRONIC 50		
Bolt Size	Maximum torque	Recommended minimum torque
Standard	Nm	Nm
M4	5	3
M5	9	7
M6	16	11
M8	38	28
M10	76	55
M12	132	95
M14	211	152
M16	327	236
M20	639	461
M24	1104	797
M30	2195	1585
M36	3837	2771
M42	6144	4437
M48	9228	6665

**Table-2: End Plate Fastener (B913a)**  
CL 150/300

Valve Size	Torque (Nm)	
	Max	Recommended (Min)
3"	25	15
4"	25	15
6"	25	15
8"	35	25
10"	35	25
12"	35	25
14"	35	25
16"	50	30
18"	80	40
20"	80	40
24"	80	40
28"	80	40
30"	100	50
32"	100	50
36"	120	60
48"	120	60

**Table-3: Seat Ring Fastener (B913b)**  
CL 150/300

Valve Size	Torque (Nm)	
	Max	Recommended (Min)
3"	10	8
4"	10	8
6"	10	8
8"	15	10
10"	25	15
12"	25	15
14"	25	15
16"	30	20
18"	50	25
20"	50	25
24"	80	40
28"	80	40
30"	100	50
32"	100	50
36"	120	60
48"	120	60

**Table-4: End Plate Fastener (B913a)**  
CL600

Valve Size	Torque (Nm)	
	Max	Recommended (Min)
3"	30	25
4"	30	25
6"	50	30
8"	80	40
10"	100	50
12"	100	50
14"	100	50
16"	150	60
18"	150	60
20"	150	60
24"	200	80

**Table-5: Seat Ring Fastener (B913b)**  
CL 600

Valve Size	Torque (Nm)	
	Max	Recommended (Min)
3"	13	10
4"	30	15
6"	50	20
8"	50	20
10"	75	25
12"	100	40
14"	150	50
16"	150	50
18"	150	50
20"	200	60
24"	200	60

# Direct Sales Office Locations

**Australia**

Brisbane  
Phone: +61-7-3001-4319

Perth  
Phone: +61-8-6595-7018

Melbourne  
Phone: +61-3-8807-6002

**Brazil**

Phone: +55-19-2104-6900

**China**

Phone: +86-10-5738-8888

**France**

Courbevoie  
Phone: +33-1-4904-9000

**India**

Mumbai  
Phone: +91-22-8354790

New Delhi

Phone: +91-11-2-6164175

**Italy**

Phone: +39-081-7892-111

**Japan**

Tokyo  
Phone: +81-03-6871-9008

**Korea**

Phone: +82-2-2274-0748

**Malaysia**

Phone: +60-3-2161-03228

**Mexico**

Phone: +52-55-3640-5060

**Russia**

Veliky Novgorod  
Phone: +7-8162-55-7898

Moscow

Phone: +7-495-585-1276

**Saudi Arabia**

Phone: +966-3-341-0278

**Singapore**

Phone: +65-6861-6100

**South Africa**

Phone: +27-11-452-1550

**South & Central  
America and the Caribbean**

Phone: +55-12-2134-1201

**Spain**

Phone: +34-935-877-605

**United Arab Emirates**

Phone: +971-4-8991-777

**United Kingdom**

Phone: +44-7919-382-156

**United States**

Houston, Texas  
Phone: +1-713-966-3600

**Find the nearest local Channel Partner in your area:**

[valves.bakerhughes.com/contact-us](http://valves.bakerhughes.com/contact-us)

## Tech Field Support & Warranty:

Phone: +1-866-827-5378

[valvesupport@bakerhughes.com](mailto:valvesupport@bakerhughes.com)

[valves.bakerhughes.com](http://valves.bakerhughes.com)

Copyright 2020 Baker Hughes Company. All rights reserved. Baker Hughes provides this information on an "as is" basis for general information purposes. Baker Hughes does not make any representation as to the accuracy or completeness of the information and makes no warranties of any kind, specific, implied or oral, to the fullest extent permissible by law, including those of merchantability and fitness for a particular purpose or use. Baker Hughes hereby disclaims any and all liability for any direct, indirect, consequential or special damages, claims for lost profits, or third party claims arising from the use of the information, whether a claim is asserted in contract, tort, or otherwise. Baker Hughes reserves the right to make changes in specifications and features shown herein, or discontinue the product described at any time without notice or obligation. Contact your Baker Hughes representative for the most current information. The Baker Hughes logo and Masoneilan are trademarks of Baker Hughes Company. Other company names and product names used in this document are the registered trademarks or trademarks of their respective owners.

**Baker Hughes** 